

VR CNC Turning

PROGRAMMING FEATURES

- Customisable docking toolbars.
- Comprehensive tooling management.
- Colour formatting of NC code.
- Powerful NC Code modification options.
- Context sensitive G&M code help.

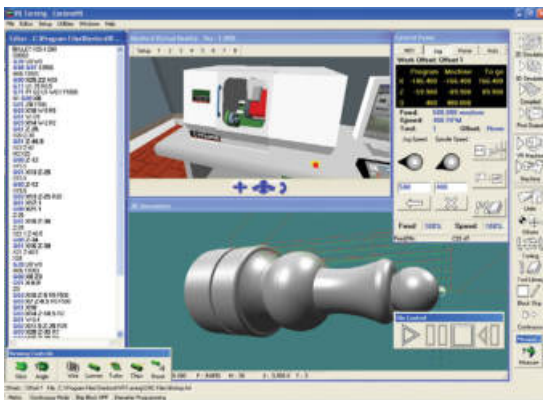

VR SIMULATION FEATURES

- Dynamic rotation/zooming.
- Colour coded move types and tooling.
- Built in Virtual Micrometer to measure the simulated workpiece.
- Unique “SourceTrack” technology for interaction between graphical data and NC Code.

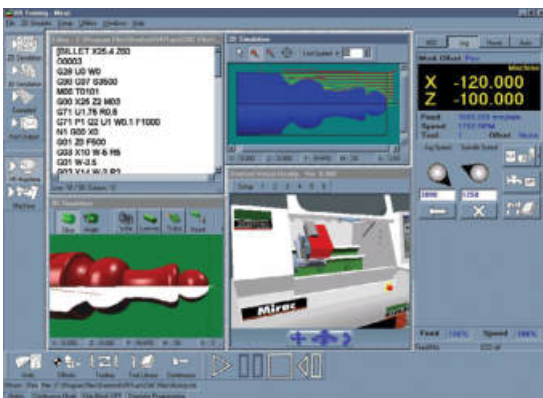

MACHINE CONTROL FEATURES

VR CNC Turning is recommended for physical control of the full range of Denford CNC Lathes. Password protected machine parameters allows tailoring to suit individual machines.

The Denford Post Processor allows translation of NC programs between different controller types.

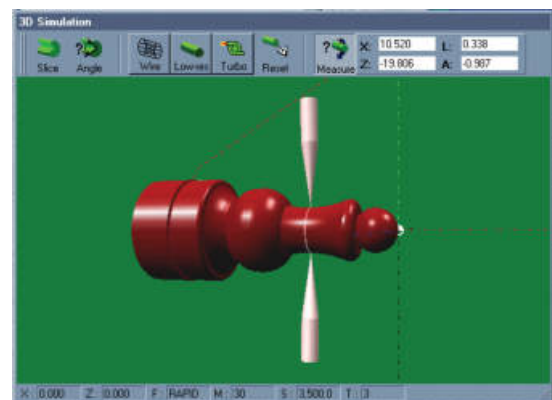

VIRTUAL REALITY FEATURES

Virtual Reality control encourages students to familiarise themselves with machining processes before physical manufacture. Includes a fully working Automatic Turret and library of machine options.

RECOMMENDED SYSTEM REQUIREMENTS

2 GHz Processor,

4 GB Memory,

64 GB Hard Disk,

Microsoft Windows 7, 8, 10 & 11

OpenGL Graphics Card, or built in Graphics, to support a minimum 1024 x 768 Screen Resolution,

CNC machines require Ethernet or USB Connection.

QuickTURN 2D DESIGN

CAD/CAM DESIGN AND MANUFACTURE
SOFTWARE FOR LATHES

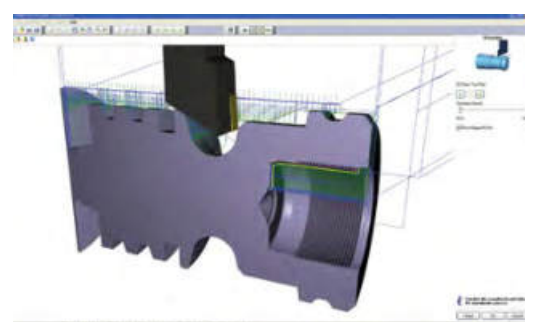
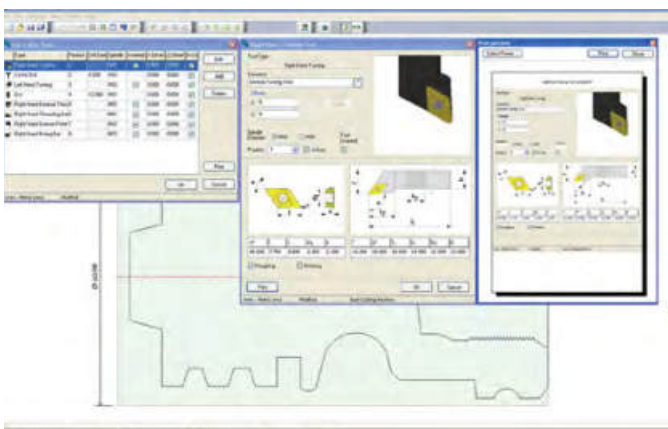
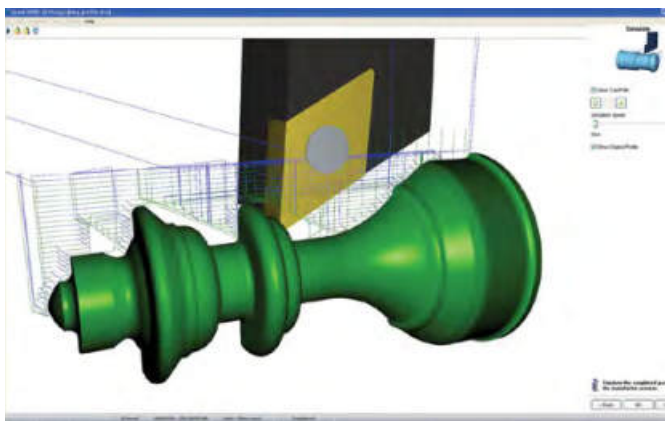
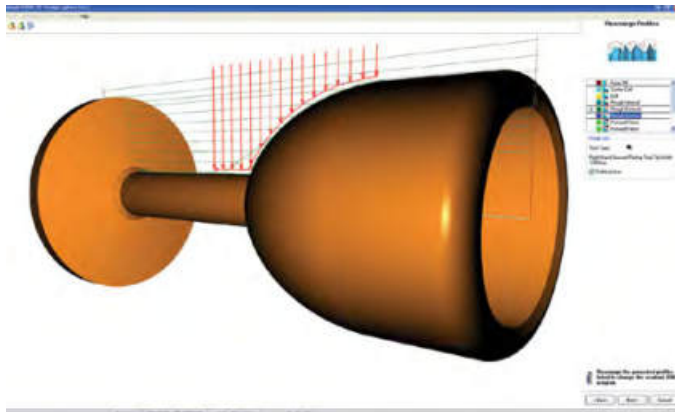

QuickTURN is an advanced yet simple to use, wizard based CAD/CAM package for Lathes. You can create or import 2D profiles, configure your tooling and material settings, then run the CAM wizard to create and simulate CNC Lathe toolpaths. The software features fully automatic toolpath generation, picking the most suitable tool from those available.

QuickTURN 2D Design

PROFILE DRAWING FEATURES

- Create lines, arcs and threads on external and internal profiles.
- Geometry is limited to the billet size and interacts with the rest of the profile to inhibit the creation of profiles that would be impossible to machine (eg, overhangs or breaking through from the internal profile).
- DXF file import wizard allows designs from other CAD software to be turned into a profile ready for the CAM wizard.
- Profile items can be edited interactively on screen, or by the property editor.
- Profile dimensions update constantly.

TOOLING AND MATERIAL OPTIONS

- The tooling editor allows a wide range of tool types to be edited or created and features a live 3D preview of the tool.
- The shape and size of tool tips and holders can be defined exactly as they are in the real world for a more realistic simulation.
- Tools can be quickly deactivated so the CAM wizard will not pick them.
- Material types can be configured quickly and easily to include feed, speed and cut depth settings for each of the tools available.
- Default feed and speed settings for all tool types can be edited quickly by a unique override slide bar.
- Tooling and material details can be printed out in summary or full detail.

RECOMMENDED SYSTEM REQUIREMENTS

1 GHz Processor,
 1 GB Memory,
 32 GB Hard Disk,
 Microsoft Windows 7, 8 & 10,
 OpenGL Graphics Card, or built in Graphics,
 to support a minimum 1024 x 768 Screen Resolution,
 CNC machines require USB Connection.

CAM WIZARD FEATURES

Material selector to alter feed, speed and cut depths.

Billet material size editor in case the actual material is larger than the design.

Tooling selector quickly allows certain tools to be deactivated.

Toolpath generator automatically picks the tools and creates all internal/external cutting and threading operations.

Tool nose radius compensation is automatically applied to the generated toolpath for any turning, boring and grooving tools.

A 3D preview of the design also shows the generated toolpaths.

Each set of toolpaths can be deactivated if not required by the rearrange profile editor.

Toolpaths are post-processed to a CNC file suitable for a Denford Lathe.

A fully animated 3D cutting simulation of the tool paths lets you verify that the CNC program is ok.

